

B40D & B35D

A R T I C U L A T E D T R U C K S



Great Value starts with the best of the best.

The design of the D-series brings together the very best in power and drivetrain technology and efficient, innovative design.

This is not an overnight phenomenon.

It has evolved through four generations of strong reliable trucks. Trucks built on the vision that by combining the best of the best in components and design, lasting value is created.



Squeezing more work from every drop of fuel...

...begins with a ultra modern engine. The Mercedes Benz OM501LA is a technological master piece.

With 4 valve technology, electronically managed unit injectors and ultra high (8000 bar) injection pressures, the D-series' power plant achieves low specific fuel consumption and emissions that will comply with even future legislation. In addition the 501LA delivers power at a lower RPM further conserving fuel. Clean burning fuel efficient technology at its best and Mercedes achieves this in a power density package some 38% better than the closest competitor.

Through Allison's proprietary world series transmission technology, which achieves 6 ideally spaced speeds with one less planetary gear set, the D-series gets more power to the ground. Smoothly. Fuel savings from an efficient drivetrain are maximized by Bell Equipment's

innovative weight saving design focus.

From the low overhang front end to the ribbed load body, extensive use of high strength steel and composite materials, the D-series carries less dead weight. More Payload. The D-series' payload to weight ratio advantage delivers more tonnes per unit of fuel used.



Faster Cycles Greater Payloads...More Production on every shift

While the B40D's new generation engine features a modest increase in power, the beauty of this new technology is 308 net kW, available at just 1 800 rpm. With 2000Nm torque developed at a low 1 080 rpm. The B35D's power has increased 13% to 283 net kW with 1 824Nm of torque.

This broad usable power band coupled with an improved power to weight ratio delivers a remarkable performance advantage. Evenly spaced ratio steps and uninterrupted power flow during shifts help maximize this advantage.

At the other end of the cycle, superior retarding and braking capacity is also key to greater productivity. The B40D's new oil cooled multi disc brakes reduce stopping distances by 20%, are unaffected by environmental conditions and will go up to 10 000 hours between services.

For wear, free speed control down gradients, and in fact, for all rapid deceleration throughout the cycle, the B40D has highly effective engine and transmission retarding systems.

The transmission has an output type retarder which is most effective at high vehicle speeds. Precisely when its needed. At the same time in retarding mode, the transmission is programmed to downshift, maximizing engine rpm, and the quiet yet powerful Mercedes

Engine Valve Brake system (EVB). Together these systems provide as much as 800 kW of retarding power for unsurpassed down haul productivity.

The B35D features new ventilated dry disc brakes. Eight heavy duty calipers ensure dependable stopping power.

Quick acceleration, fast haul speed, rapid braking, 20% faster dump cycle and an extra half tonne payload. With the D-series the solution for more production is not more trucks. Just more truck.

Superior Performance and an optimised, modern cab to command it from

There're a lot of ideas out there on how modern work stations should be designed. Bell engineers used the best of them and built the new D-series cabin in first class style.

Happy operators make happy operations. Along with a pleasing ergonomic layout, responsive effortless controls, improved vision out, a more powerful climate control system, they added a few extras that turns the cockpit into the 'corner office'.

Like remote adjusted rear view mirrors. Lots of handy storage space including a compartment that uses the HVAC system to provide a cool drink in summer or warm a meal in winter.

With quieter cabin sound levels of 76 db the D-series' operator can not only concentrate on productivity, he can measure it. The monitor display unit shows recorded cycle data, fuel use and all important operating conditions. If desired, available integrated on board scales will keep precise tally of production. At the same time the D-series' controls are simple and foolproof. Traction control is activated by just 2 switches. The touchpad transmission controller is fully protected

against accidental misselection.

In the D-series even new operators pick up production quickly. All this and the smooth ride from the nitrogen over oil strut suspension system make the B40D the **operators truck in every respect.**

Fewer service points extended service intervals...

...more component protection - pay back time for technology.

Engineering advances have cut service and maintenance needs on the D-series. Innovative design provides quick access to all systems and components. Easy to work on features, appreciated by service personnel.

Because prevention is better than cure, protection provided by full authority electronic control is a long term benefit built into the D-series. The electronic controllers of the engine and the transmission are networked by CANbus to the chassis control unit. Careful attention to the finer details, robust connectors, protected harnesses and secure restraints ensure lifelong reliability.

Maximum protection against malfunctions is built in. Should an operating parameter look like going out of range, the controller reduces power or limit shifts as appropriate to prevent damage. As this operating condition is stored by the ECM retrieving information to pin point problems is as simple as pushing a button.

With the D-series **pay back from technology is peace of mind.**





Built for the **Long Run**

...and absolutely the lowest cost per tonne

Many factors contribute to the D-series' unsurpassed long term economics.

For a start the 500 series power plant is engineered with a B10/service life some 50% greater than its predecessor. Up to 20 000 hours to first major overhaul.

Because all major components are manufactured in volume Bell truck users are not held captive to exotic components or astronomical parts prices. Bell trucks continue to produce cost effectively beyond traditional economic life.

From the first day on the job the D series will deliver extra production economically with a long life ahead. The bottom line absolutely the lowest cost per ton in the business.

B40D SPECIFICATIONS		B35D SPECIFICATIONS	
ENGINE <i>Configuration</i> <i>Aspiration</i> <i>Cooling System</i>	Mercedes Benz OM501LA V-6 Turbocharged and intercooled Liquid cooled with single pass radiator as well as charge air cooler	Mercedes Benz OM501LA V-6 Turbocharged and intercooled Liquid cooled with single pass radiator as well as charge air cooler	Mercedes Benz OM501LA V-6 Turbocharged and intercooled Liquid cooled with single pass radiator as well as charge air cooler
<i>Gross Power</i> <i>Net Power</i> <i>Gross Torque</i> <i>Net torque</i> <i>Displacement</i> <i>Fuel tank capacity</i>	315 kW (422 hp) @ 1 800 rpm SAE J1349 308 kW (413 hp) @ 1 800 rpm 2 000 Nm (1,473 lb ft) @ 1 080 rpm SAE J1349 1 974 Nm (1,453 lbf) @ 1 080 rpm 11,95 litres (730 cu.in) 485l (128 US gal)	290 kW (389 hp) @ 1 800 rpm SAE J1349 283 kW (380 hp) @ 1 800 rpm 1 850 Nm (1,362 lbf) @ 1 080 rpm SAE J1349 1 824 Nm (1,343 lbf) @ 1 080 rpm 11,95 l (730 cu.in) 485 l (128 US gal)	290 kW (389 hp) @ 1 800 rpm SAE J1349 283 kW (380 hp) @ 1 800 rpm 1 850 Nm (1,362 lbf) @ 1 080 rpm SAE J1349 1 824 Nm (1,343 lbf) @ 1 080 rpm 11,95 l (730 cu.in) 485 l (128 US gal)
TRANSMISSION <i>Layout</i> <i>Gear layout</i> <i>Gears</i> <i>Clutch type</i> <i>Control type</i> <i>Torque converter layout</i> <i>Vehicle speeds</i>	Allison HD4560 with integral retarder Engine mounted box with rear output Constant meshing planetary gears, clutch operated. 6 Forward, 1 Reverse Hydraulically operated multi-disc Electronic Hydrodynamic with lock-up in all gears 1st 2nd 3rd 4th 5th 6th R 7,4 15,7 22,8 34,8 45,6 52,0 6,3 km/h (4.6) (9.8) (14.3) (21.8) (28.5) (32.5) (3.9) mph	Allison HD4560 Engine mounted box with rear output Constant meshing planetary gears, clutch operated. 6 Forward, 1 Reverse Hydraulically operated, multidisc Electronic Hydrodynamic with lock-up in all gears 1st 2nd 3rd 4th 5th 6th R 7,8 16,5 24,0 36,6 47,9 54,4 6,3 km/h (4.9) (10.3) (15.0) (22.8) (29.9) (34.0) (4.1) mph	Allison HD4560 Engine mounted box with rear output Constant meshing planetary gears, clutch operated. 6 Forward, 1 Reverse Hydraulically operated, multidisc Electronic Hydrodynamic with lock-up in all gears 1st 2nd 3rd 4th 5th 6th R 7,8 16,5 24,0 36,6 47,9 54,4 6,3 km/h (4.9) (10.3) (15.0) (22.8) (29.9) (34.0) (4.1) mph
TRANSFER CASE <i>Layout</i> <i>Output differential</i>	VGR 17000 Three in-line helical gears. Interaxle 33/67 proportional differential, pneumatically lockable whilst stationary or on the move.	VGR 17000 Three in-line helical gears. Interaxle 33/67 proportional differential, pneumatically lockable whilst stationary or on the move.	VGR 17000 Three in-line helical gears. Interaxle 33/67 proportional differential, pneumatically lockable whilst stationary or on the move.
AXLES <i>Differential type</i> <i>Final drive type</i> <i>Housing type</i>	Bell 25 tonne Spiral bevel type with Controlled Traction Differentials (CTD) Outboard heavy-duty planetary Steel fabricated	Bell 25 tonne Spiral bevel type with Controlled Traction Differentials (CTD) Outboard heavy-duty planetary Steel fabricated	Bell 25 tonne Spiral bevel type with Controlled Traction Differentials (CTD) Outboard heavy-duty planetary Steel fabricated
BRAKING SYSTEM <i>Service Brake</i> <i>Maximum Brake Force</i> <i>Park & Emergency</i> <i>Maximum brake force</i> <i>Auxiliary Brake</i> <i>Maximum Retardation</i>	Dual circuit, full hydraulic actuation wet disc brakes on front and middle axles 218 kN (49,010 lbf) Spring applied, air released driveline mounted disc. 440 kN (98,920 lbf) Automatic exhaust brake and Engine Valve Brake (EVB) 830 kW (1,113 hp)	Dual circuit, full hydraulic actuation caliper brakes on all wheels 193 kN (43,390 lbf) Spring applied, air released driveline mounted disc. 440 kN (98,910 lbf) Automatic exhaust brake and Engine Valve Brake (EVB) 270 kW (362 hp)	Dual circuit, full hydraulic actuation caliper brakes on all wheels 193 kN (43,390 lbf) Spring applied, air released driveline mounted disc. 440 kN (98,910 lbf) Automatic exhaust brake and Engine Valve Brake (EVB) 270 kW (362 hp)
WHEELS <i>Tyre</i> <i>Size</i> <i>Type</i> <i>Max ground pressure</i> <i>(laden)</i>	29.5R25 Radial Earthmover 156 kPa (23 psi)	26.5R25 Radial Earth Mover 156 kPa (23 psi)	26.5R25 Radial Earth Mover 156 kPa (23 psi)
SUSPENSION <i>Front type</i> <i>Rear type</i>	Semi-independent leading A-frame supported by nitrogen/oil struts Pivoting walking beams equalize the load on each axle with laminated suspension blocks. Each axle is coupled to the chassis by a Tri-Link system of four rubber-bushed links for ideal vertical movement and a transverse link for lateral restraint.	Semi-independent leading A-frame supported by nitrogen/oil struts Pivoting walking beams equalize the load on each axle with laminated suspension blocks. Each axle is coupled to the chassis by a Tri-Link system of four rubber-bushed links for ideal vertical movement and a transverse link for lateral restraint.	Semi-independent leading A-frame supported by nitrogen/oil struts Pivoting walking beams equalize the load on each axle with laminated suspension blocks. Each axle is coupled to the chassis by a Tri-Link system of four rubber-bushed links for ideal vertical movement and a transverse link for lateral restraint.
HYDRAULIC SYSTEM <i>Pump type</i> <i>Application</i> <i>Flow:</i> <i>Pressure:</i> <i>Filter:</i>	Full load sensing system serving the prioritized steering, body tipping and brake functions. A ground-driven, load sensing emergency steering pump is integrated into the main system. Variable displacement, load sensing piston Steering, tipping, hydraulic brake charging and cooling fan drive 300 l/min (79,26 US gal/min) 25 Mpa (3,626 psi) 10 micron	Full load sensing system serving the prioritized steering, body tipping and brake functions. A ground- driven, load sensing emergency steering pump is integrated into the main system Variable displacement, load sensing piston Application Steering, tipping, hydraulic brake charging and cooling fan drive 300 l/min (79.26 US gal/min) 25 Mpa (3,626psi) 10 micron	Full load sensing system serving the prioritized steering, body tipping and brake functions. A ground- driven, load sensing emergency steering pump is integrated into the main system Variable displacement, load sensing piston Application Steering, tipping, hydraulic brake charging and cooling fan drive 300 l/min (79.26 US gal/min) 25 Mpa (3,626psi) 10 micron
PNEUMATIC SYSTEM <i>System pressure</i>	Air drier with heater and integral unloader valve, serving park brake and auxiliary functions 810 kPa (117 psi)	Air drier with heater and integral unloader valve, serving park brake and auxiliary functions 810 kPa (117 psi)	Air drier with heater and integral unloader valve, serving park brake and auxiliary functions 810 kPa (117 psi)

B40D SPECIFICATIONS		B35D SPECIFICATIONS	
ELECTRICAL SYSTEM <i>Voltage</i> <i>Battery type</i> <i>Battery capacity</i> <i>Alternator rating</i>	24V Two maintenance free permanently sealed 2 x 105 Ah (optional 2 extra batteries) 28 V 100 A	24V Two maintenance free permanently sealed 2 x 105 Ah (optional 2 extra batteries) 28 V 100 A	24V Two maintenance free permanently sealed 2 x 105 Ah (optional 2 extra batteries) 28 V 100 A
STEERING SYSTEM <i>Angle</i> <i>Lock to lock turns</i>	Hydrostatically actuated by two double acting cylinders, with ground-driven emergency steering pump. +- 42 degrees 4,7	Hydrostatically actuated by two double acting cylinders, with ground-driven emergency steering pump. +- 42 degrees 4,7	Hydrostatically actuated by two double acting cylinders, with ground-driven emergency steering pump. +- 42 degrees 4,7
BODY <i>Capacity: Struck</i> <i>Heaped: SAE 2:1</i> <i>SAE 1:1</i> <i>Rated payload</i> <i>Power down time</i> <i>Raise time</i> <i>Tipping angle</i>	Struck 16,9 m ³ (22.1 cu.yd) 22,5 m ³ (29.4 cu.yd) 27,4 m ³ (35.8 cu.yd) 37 000 kg (81,571 lbs) 7,6 s 13 s 70 degrees	Struck 15,2 m ³ (19.9 cu.yd) 20 m ³ (26.2 cu.yd) 24,6 m ³ (32.2 cu.yd) 32 500kg (71,650 lbs) 7,6 s 13 s 70 degrees	Struck 15,2 m ³ (19.9 cu.yd) 20 m ³ (26.2 cu.yd) 24,6 m ³ (32.2 cu.yd) 32 500kg (71,650 lbs) 7,6 s 13 s 70 degrees
OPERATING WEIGHTS <i>Empty:</i> <i>Front</i> <i>Middle</i> <i>Rear</i> <i>Total</i> <i>Laden:</i> <i>Front</i> <i>Middle</i> <i>Rear</i> <i>Total</i>	14 615 kg (32,230 lbs) 7 280 kg (16,050 lbs) 6 955 kg (15,340 lbs) 28 850 kg (63,620 lbs) 19 395 kg (42,770 lbs) 23 390 kg (51,570 lbs) 23 065 kg (50,860 lbs) 65 850 kg (145,200 lbs)	13 600 kg (29,990 lbs) 6 565 kg (14,480 lbs) 6 560 kg (14,470 lbs) 26 725 kg (58,940 lbs) 18 510 kg (40,820 lbs) 20 360 kg (44,890 lbs) 20 355 kg (44,880 lbs) 59 225 kg (130,590 lbs)	13 600 kg (29,990 lbs) 6 565 kg (14,480 lbs) 6 560 kg (14,470 lbs) 26 725 kg (58,940 lbs) 18 510 kg (40,820 lbs) 20 360 kg (44,890 lbs) 20 355 kg (44,880 lbs) 59 225 kg (130,590 lbs)
STANDARD EQUIPMENT	Cab • ROPS/FOPS certification • Protective rear window guard • Handrails on fenders • Tilt cab for service access • Gas strut supported door • Tinted safety glass • Sliding windows • Rear view mirrors- regular and wide angle • Electric adjust and heated mirrors (one per side) • Sun visor • Wiper/washer with intermittent control • Tilt and telescoping steering wheel • Adjustable, air suspension seat with retractable seat belt • Fold-away trainer seat with retractable seat belt • HVAC climate control system with filtered and ducted air • Air horn • Over head console for FM and 2-way radio, compartments for, storage electrical relays and circuit breakers • 12 V power outlet/12 V cigarette lighter • Ash tray • Drinks holder • Cooled/heated lunch box • Wheel spanner set • MDU Features • Tipping counter • Trip timer • Trip distance • Fuel Consumption • Diagnostics • Intermittent wiper timing control • Speedo calibration for alternative tyre sizes • Metric /Imperial unit selection • Warning lights with audible buzzer • Analogue Gauges • Engine coolant temperature • Engine oil pressure • System air pressure • Transmission oil temperature • Fuel • Speedometer • LCD Display • Transmission gear selection • Tachometer • Battery voltage • Hourmeter • Odometer • Retarder • Integral transmission output retarder with 6 settings • Brakes • Oil Immersed wet multi-disc on front and middle axles • Fully hydraulically actuated • Spring applied air release park brake on rear driveshaft • Other Ground driven emergency steering	Cab • ROPS/FOPS certification • Protective rear window guard • Handrails on fenders • Tilt cab for service access • Gas strut supported door • Tinted safety glass • Sliding windows • Rearview mirrors- regular and wide angle • Sun visor • Wiper/washer with intermittent control • Tilt and telescoping steering wheel • Adjustable, air suspension seat with retractable seat belt • Fold-away trainer seat with retractable seat belt • HVAC climate control system with filtered and ducted air • Air horn • Over head console for FM and 2-way radio, compartments for, storage electrical relays and circuit breakers • 12V power outlet/12V cigarette lighter • Ash tray • Drinks holder • Cooled/heated lunch box • Wheel spanner set • MDU Features • Tipping counter • Trip timer • Trip distance • Fuel Consumption • Diagnostics • Intermittent wiper timing control • Speedometer calibration for alternative tyre sizes • Metric /Imperial unit selection • Warning lights with audible buzzer • Analogue Gauges • Engine coolant temperature • Engine oil pressure • System air pressure • Transmission oil temperature • Fuel • Speedometer • LCD Display • Transmission gear selection • Tachometer • Battery voltage • Hourmeter • Odometer • Brakes • Dry disc on all 6 wheels • Fully hydraulically actuated • Spring applied air release park brake on rear driveshaft • Other Ground driven emergency steering	Cab • ROPS/FOPS certification • Protective rear window guard • Handrails on fenders • Tilt cab for service access • Gas strut supported door • Tinted safety glass • Sliding windows • Rearview mirrors- regular and wide angle • Sun visor • Wiper/washer with intermittent control • Tilt and telescoping steering wheel • Adjustable, air suspension seat with retractable seat belt • Fold-away trainer seat with retractable seat belt • HVAC climate control system with filtered and ducted air • Air horn • Over head console for FM and 2-way radio, compartments for, storage electrical relays and circuit breakers • 12V power outlet/12V cigarette lighter • Ash tray • Drinks holder • Cooled/heated lunch box • Wheel spanner set • MDU Features • Tipping counter • Trip timer • Trip distance • Fuel Consumption • Diagnostics • Intermittent wiper timing control • Speedometer calibration for alternative tyre sizes • Metric /Imperial unit selection • Warning lights with audible buzzer • Analogue Gauges • Engine coolant temperature • Engine oil pressure • System air pressure • Transmission oil temperature • Fuel • Speedometer • LCD Display • Transmission gear selection • Tachometer • Battery voltage • Hourmeter • Odometer • Brakes • Dry disc on all 6 wheels • Fully hydraulically actuated • Spring applied air release park brake on rear driveshaft • Other Ground driven emergency steering
OPTIONAL EQUIPMENT	(Factory and field installed) • Exhaust body heating • Groeneveld Central lubrication system • Cable autogate • "M" type rock application body • Body liners • Flashing beacon • Work lights • Artic reverse light • Electrical horn • 2 extra batteries • Fuel filter heating element • Provision for: FM and 2-way radios • Reverse camera and alarm • Wiggins quick fuelling system	(Factory and field installed) • Exhaust body heating • Groeneveld central lubrication system • Cable autogate • "M" type rock application body • Body liners • Flashing beacon • Work lights • Artic reverse light • Electrical horn • 2 extra batteries • Fuel filter heating element • Provision for: FM and 2-way radios • Reverse camera and alarm • Wiggins quick fuelling system	(Factory and field installed) • Exhaust body heating • Groeneveld central lubrication system • Cable autogate • "M" type rock application body • Body liners • Flashing beacon • Work lights • Artic reverse light • Electrical horn • 2 extra batteries • Fuel filter heating element • Provision for: FM and 2-way radios • Reverse camera and alarm • Wiggins quick fuelling system

B40D
SPECIFICATIONS

**GRADEABILITY/
RIMPULL**

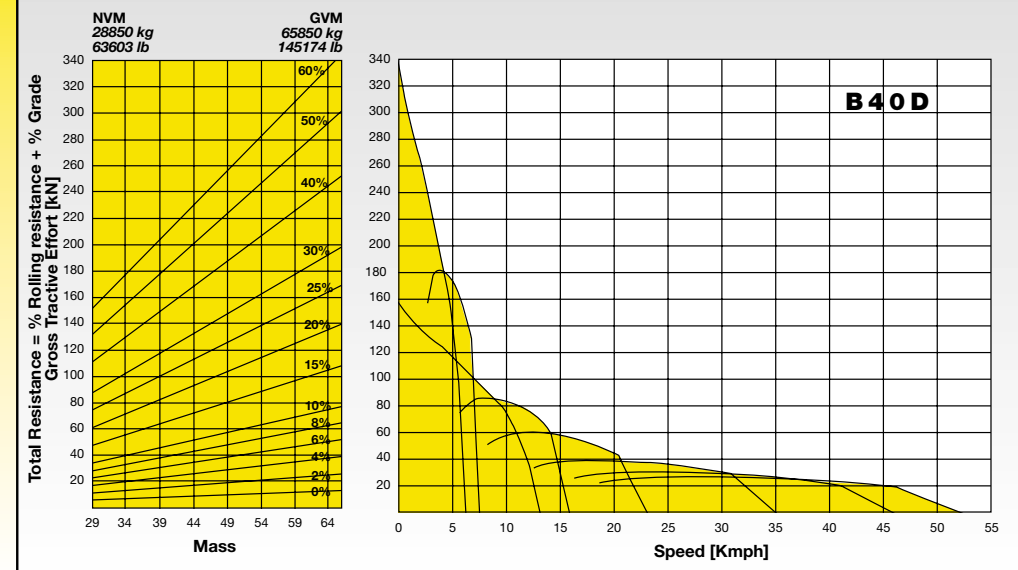

RETARDATION

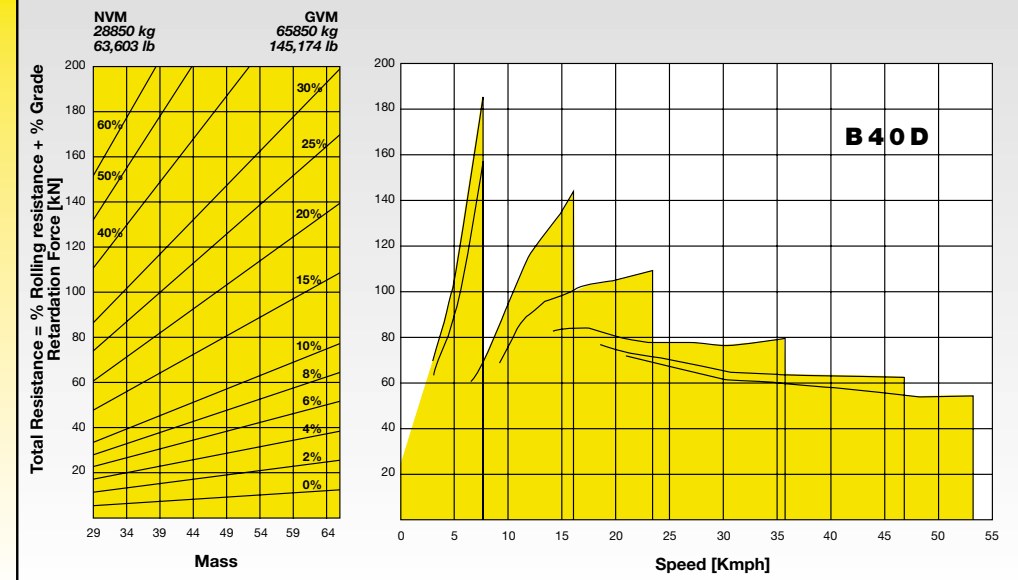

**SAE TURNING RADIUS
DIMENSIONS**

A Inside turning circle radius

4894mm (16ft.0in)

B Outside turning circle radius

9203mm (30ft.2in)

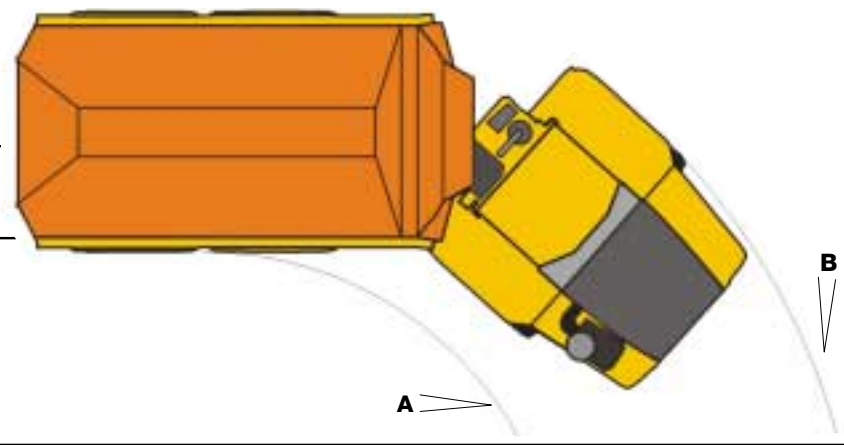

B35D
SPECIFICATIONS

**GRADEABILITY/
RIMPULL**

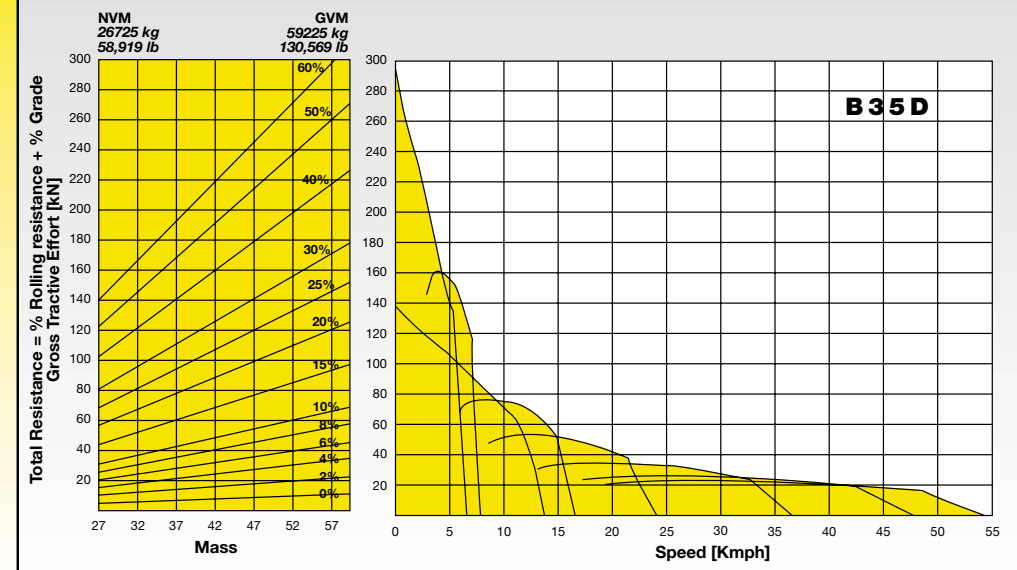

RETARDATION

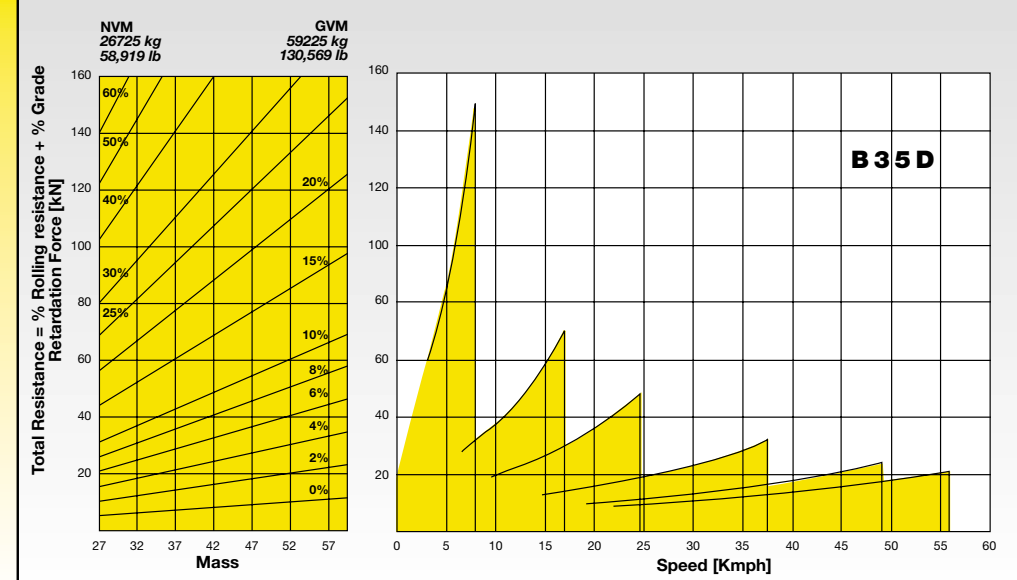

**SAE TURNING RADIUS
DIMENSIONS**

A Inside turning circle radius

5055mm (16ft.7in)

B Outside turning circle radius

9132mm (29ft.11.5in.)

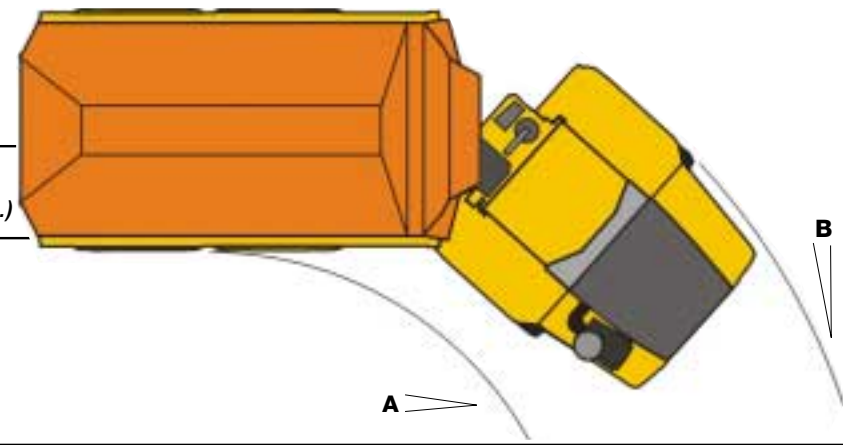

B40D
SPECIFICATIONS

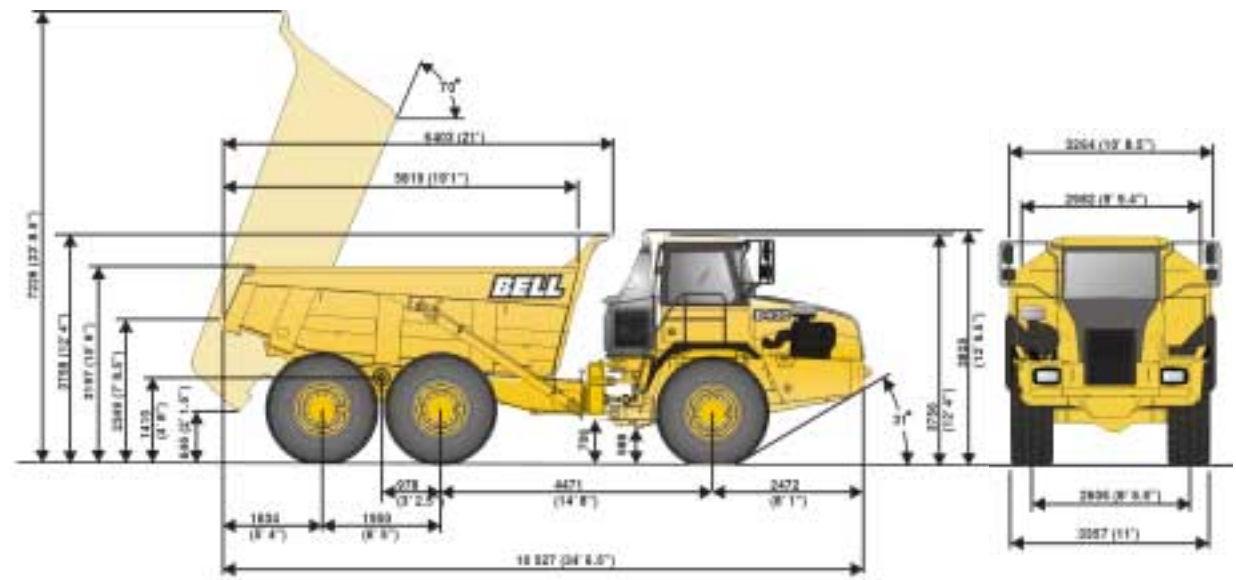

B35D
SPECIFICATIONS

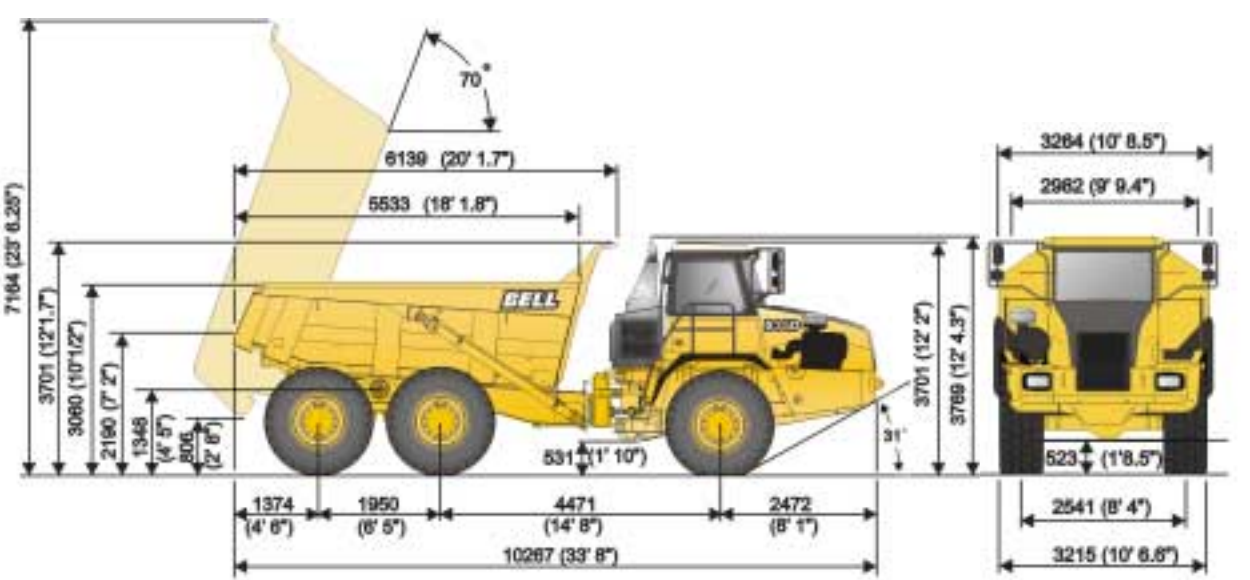

notes

Environmental Statement

Bell Equipment places environmental responsibility amongst its core values and recognizes the importance of preserving the integrity of our natural heritage.

Our care for the environment shall form an integral part of our operations and all employees will be encouraged to enthusiastically embrace care for the environment as a cornerstone of their jobs.

In designing and manufacturing our products we will aim that:

- Our manufacturing operations are conducted in a manner which ensures that all industrial effluent and waste products are managed so as to minimize their impact on the environment.*
- Our products will be designed so as to ensure that emissions have the least impact on the environment and that operating noise levels are minimized.*
- The environmental impact of our products shall be minimized by having due regard to their functionality in working in the industries into which they are sold.*

Bell Equipment will aim to comply with the environmental regulatory standards of all countries into which it sells its products and its concern for the environment will be subject to review of accomplishment and continuous improvement processes.



All dimensions are shown in millimetres, unless otherwise stated between brackets. Under our policy of continuous improvement, we reserve the right to change specifications and design without prior notice. Photographs featured in this brochure may include optional equipment.

BELL EQUIPMENT, Richards Bay, South Africa

• tel: 27-(0)35-907 9111 Fax: 27-(0)35-797 4323 • www.bellequipment.com

Strong Reliable Machines
Strong Reliable Support

